

Assembling Your New System

1. Unpacking: Carefully unpack your new system making sure all parts for assembly are included. If any parts are missing, call customer service for replacement.
2. Assemble Stand: Install casters and end caps first, then slide together legs and cross bar. Bolt H-frame parts together with supplied bolts. Assemble upright by sliding crimped and un-crimped sections together and inserting lock screw. With the stand sitting upright on its casters, insert upright and secure with supplied fasteners.
3. Installing Element: Lay heater-housing face up on a stable work surface. Remove end reflectors. Remove grill guard by grasping center cross wire on guard and with other hand place thumb close to the grills mounting hole. Gently press reflector away with your thumb while removing guard center wire form hole. Remove center wire from bottom. Remove guard by sliding left then right. Next, Remove element clips (#18). Carefully unpack element (it's made with quartz glass and can easily be broken). Remove one nut from the ends of element, slip ring terminals over studs and replace nuts. NOTE: Hold element ceramic firmly while tightening nuts (use two wrenches). Nuts should be snugly tightened, loose ring connections may damage element. Place element in U-channel and reinstall clips. Reassemble heater.
4. Final Assembly: Attach locking knob to rotator cross arm then assembly to heater housing with supplied tab washer and knob. Install vertical slid locking knob to cross arm and slide assembly onto upright post on stand and secure with locking knob.
5. First Use: Your Infratech curing system is ready for use. Only plug into a grounded power source.. Position the system 18" or more away from the area to be cured. Normal operating distance

SPECIFICATIONS

Model #	SRU1615HT
Part #	16-1000
Volts	120
Amps	18
Watts	2,000
Shipping WT.	24 lbs.
Length	36"

WARNING

- ◆ NEVER block front of heater ◆ DO NOT operate within 25' of flammable materials ◆
- ◆ DANGER: Do not use within 10' when spraying operations are in progress ◆
- ◆ NEVER service heater without disconnecting from power ◆
- ◆ Source of possible shock ◆ Use only with grounded power source ◆

Manufactured and Distributed By:

INFRATECH Division of Seachrome Corporation
939 North Vernon Avenue
Azusa, CA 91702
800-421-9455
Www.infratech-usa.com

SRU 1615 HT ASSEMBLY INSTRUCTIONS

Ref	Part	Description
1	13-1110	Stand Upright
2	13-1120	Stand Upright (Crimped)
3	13-1102	Stand Base Crossbar
4	13-1100	Stand Leg (left)
4	13-1101	Stand Leg (right)
5	*	Stand Frame Bolt 3/8-16 x 3/4"
6	13-1130	Caster (ea.)
*	13-1140	Stand Hardware Set
7	*	Upright Fasteners 5/16-8x11/2"
8	*	Screw # 8 Hex Head Slotted
*	14-2550	SRS-C Set of Casters
9	14-1691	Cross Arm Assembly
10	13-1090	1/4-20x9/16 "Male Knob
11,12	13-1095	Tab Washer w/ Knob
13	13-1680	End Cover / Reflector
14	*	End Cover Fastener # 6 Screw
15	10-3080	E-2012-SR Element (120V 32")
16	*	Element Fastener 8-32" Hex Nut
17	13-1010	Grill Guard
18	13-1020	Element Clip Holder
19	13-1690	HT Power Cord
*	13-1080	Speedray HT Hardware Set
*	13-1700	HT Cross Arm Assm. w / Heater
*	13-1030	Reflector
*	13-1050	Junction Box w/ Power Cord
*	13-1070	Lead Wire Set
*	13-1460	60 Min. Timer F-60-M
*	13-1600	3/8-16 x 1" Rotator Lock Knob

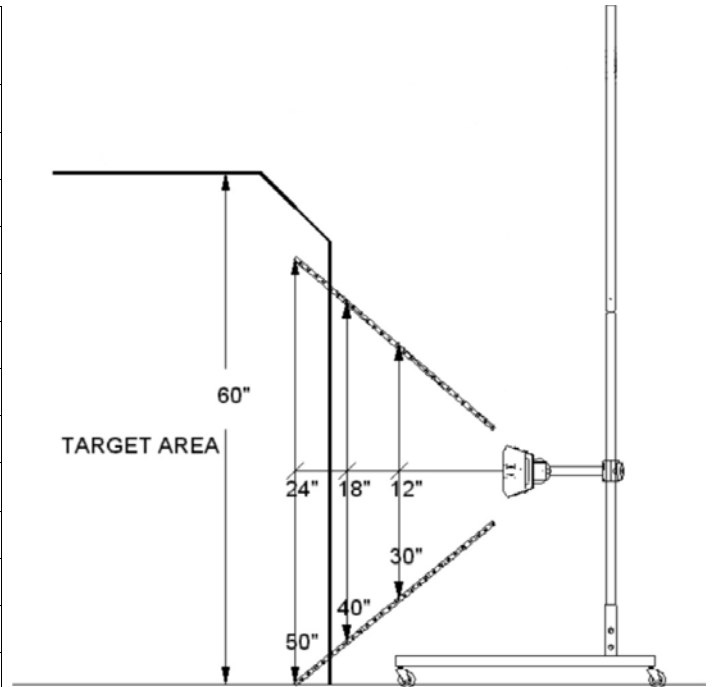

Operating Tips

Your new Infratech infrared curing system provides fast, efficient curing for virtually every type of paint, primer, body filler, bonding adhesive and plastic repair products. Infratech infrared heats from the inside out. It does not heat the air.

The way IR cure's, you first heat the coating for the prescribed time to effect solvent evacuating and cross linking, the cure cycle is complete after the heated area cools back to room temperature. Once this full cycle is complete the coating is fully cured and final assembly or cleanup for delivery can start.

Care should be taken when using your new system. Operating the system too close to the part being cure can cause damage. When you first use your system, you may want to start at a distance of 24" to 30". As you gain experience using you system, you may be able to move the system closer to apply more heat and speed the cure cycle. These heaters have enough power to blister paint and melt plastic if proper care is not exercised.

Additionally, it should be noted that different colors absorb IR at different rates; black absorbs IR far quicker than white. So darker colors may cure

2 K Primers Waterborne Base Coat Filler / Stoppers	Plastic Body Fillers 2K Plastic Repair Acrylic Enamels	2 K Top Coats High Build Primers Structural Adhesives	Polyurethane Synthetic Enamels High Solids Clear
At 18" From Surface CURE TIME 3 MIN. 2' X 3' Coverage	At 18" From Surface CURE TIME 15 MIN. 2' X 3' Coverage	At 18" From Surface CURE TIME 20 MIN. 2' X 3' Coverage	At 18" From Surface CURE TIME 18 MIN. 2' X 3' Coverage